

Caratteristiche

Icematic introduce la nuova gamma di armadi di conservazione **EF**, nati per conservare al meglio ogni prodotto. Grande potenza, versatilità, facilità d'uso ed affidabilità sono le caratteristiche più importanti degli armadi **EF**.

- Nuova scheda elettronica con comandi soft touch , display ad alta luminosità, e icone di stato/Allarme multicolore
- Modelli ventilati, con impostazione di alta e bassa umidità
- Design ergonomico
- Efficienza energetica migliorata
- Ventilatori a basso consumo energetico
- Illuminazione led
- Spessore isolamento 75 mm
- Questo armadio è destinato all'utilizzo a temperatura ambiente fino a 40°C

OPTIONAL:

- Ruote
- HACCP recorder su SD memory card
- Versione pasticceria
- Apps Android monitoraggio con connessione Bluetooth



Features

Icematic presents the new storage cabinets **EF**, born to preserve perfectly every product. Great power, versatility and extreme reliability are the most important features of the new **EF** line.

- New soft touch control panel , Large LED display with multicolors icons state / alarm, high brightness display
- Ventilated models, with high and low humidity settings
- Ergonomic design
- Improved energy efficiency
- Low energy consumption fans
- LED lighting
- Insulation thickness 75 mm
- This appliance is intended for use in ambient temperature up to 40°C

OPTIONALS :

- Wheels
- HACCP recorder with SD memory card
- Pastry version
- Apps Android monitoring with connection Bluetooth

Temperatura esercizio Working Temperature

-28°C / -15°C

Armadio ad alte prestazioni - Heavy-duty cabinet



max **36**

(Passo-Step 35 mm)
Trays GN 2/1 650 x 530 mm



max **25**

(Passo-Step 50 mm)
Trays : Pastry 600 x 400 mm



max **53**

(Passo-Step 140 mm)
Bacinielle/Basin 360x165xH125



max **30**

(Passo-Step 280 mm)
Pozzetti Diam. 200 x H250

Caratteristiche - Features

Alimentazione Elettrica / Power supply	220-240 V / 1 / 50 Hz
Codice Prodotto / Code number	EF70 NS
Lunghezza esterna / Outside length	742 mm
Profondità / Depth	918 mm
Altezza esterna / Height	2028-2083 mm
Volume netto / Net volume	463 l
Consumo energia / Energy Consumption (kW/year-anno) - [kW/24h]	(3327) - [9,11]
Indice efficienza energetica / Energy Efficiency Index (IEE)	88,6
Classe prestazioni / Classe climatic - Class of use / Climatic class	F - 5
Capacità / Capacity GN 2/1	36
Regolazione passo Teglie / Tray pitch regulation	35 mm
Compressore / Compressor	HERMETIC
Potenza Frigorifera / Refrigeration Power (-10°C/+45°C-EN12900)	1589 W
Fluido refrigerante / Refrigeration Fluid	370 g - R452A (GWP2141)
Ton CO2 equiv.	0.79
Potenza assorbita / Absorbed power	675 W - 3,5 A
Sbrinamento / Defrost	-
Peso netto/lordo net/gross Weight	145 / 165 kg
Dati spedizione / Shipment data	822 x 1046 x 2210 - 165 Kg ca.
Accessori in dotazione - Supplied Accessories	
Coppia Guide / Pairs of Slides	3
Coppia Guide / Pairs of Slides GN 2/1	3

Dimensioni- Dimensions

Vista frontale
Front view

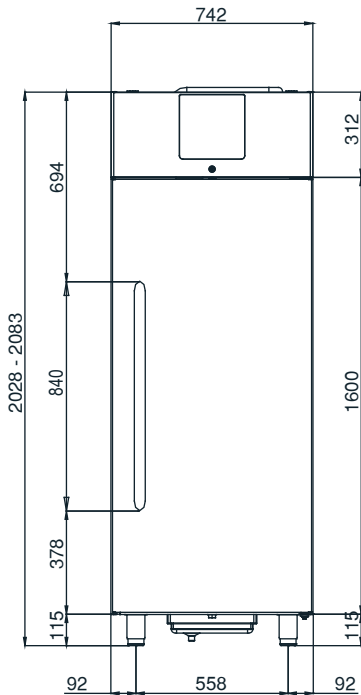

Vista laterale
Lateral view

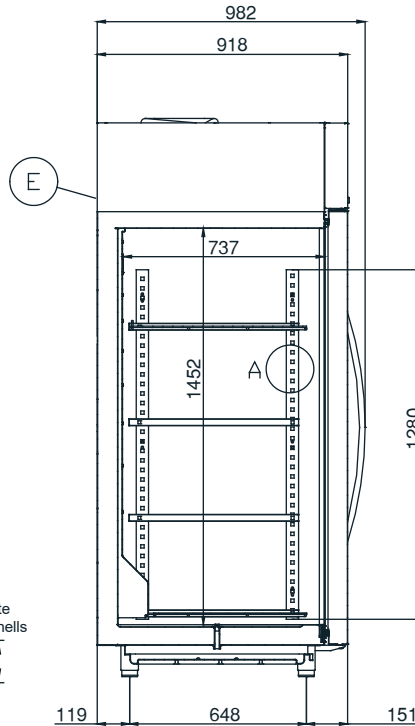

Vista superiore
Top view

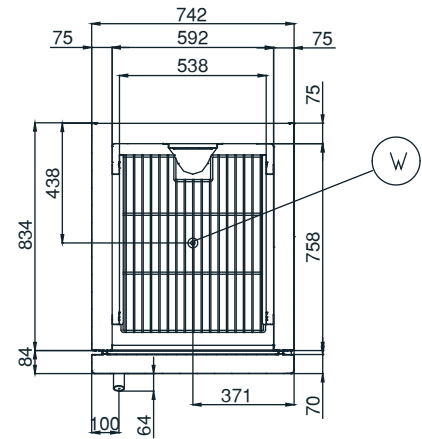

Gastronomia
Gastronorm

max 36
griglie/grids
(650x530)

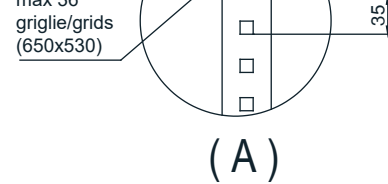

(A)

Pasticceria
Pastry

max 42
Teglie/Trays
Passo/Step
30 mm
(600x400)

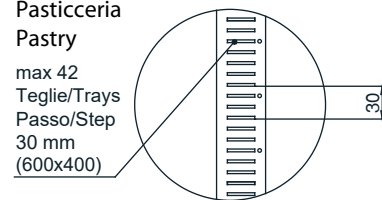

(optional)

E Alimentazione elettrica
Electrical cable supply

W Scarico acqua
Water discharge

Quadro comandi / Control panel

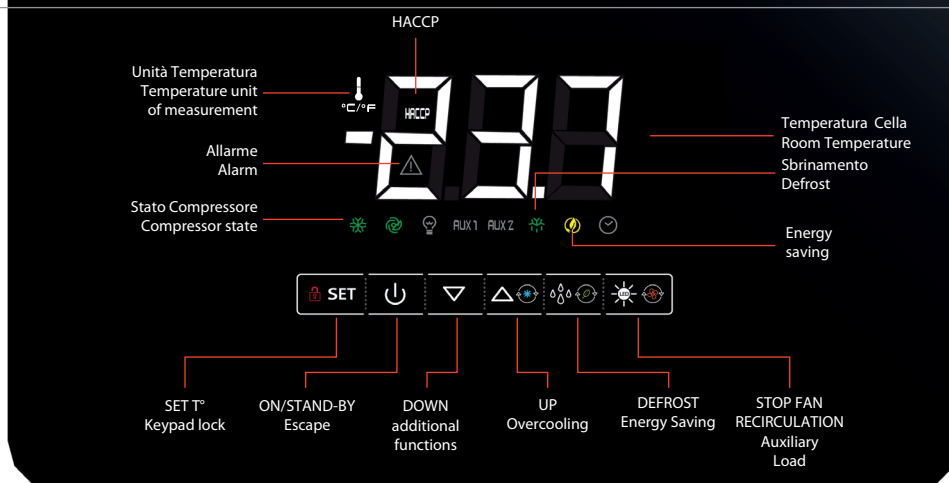

evconnect



(optional)

EF70 NS 220-240V/1N/50Hz - Armadio Refrigerato Ventilato / Ventilated Refrigerated Cabinet