

## Slope Bin 406 kg

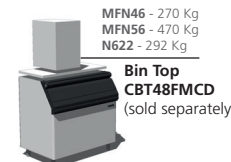
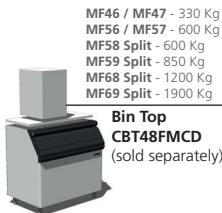
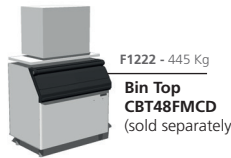
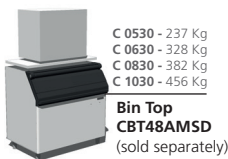
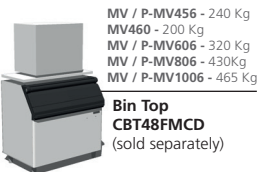

### Features

- Slope front ice storage bin, for Gourmet & Dice Cubes, Flake, Superflake, Nugget, Cubelet ice.
- New sleek, contemporary styling. A perfect match to MC, MF, MV, PMV and Prodigy Scotsman modular cube ice machines in 123cm / 48" width.
- Convenient & hygienic internal ice scoop holder.
- Exterior panels in durable stainless steel.
- Polyurethane Insulation,
- High density, non-corroding Polyethylene bin liner, is designed with easy-to-clean rounded corners, and resists scratches and scuffs from ice scoops.
- Robust door frame will resist operational abuse.
- Rounded door-lip profile allows an easy reach for enhanced ease of operation.
- Fully removable door gasket seals door opening to reduce ice melt, easily disassembled for manual cleaning.
- Internal ice deflector enhances ice distribution to maximize bin storage capacity.
- Load resistant, stainless steel adjustable legs.
- Bin Caster available on request for selected models.
- Storage bin base drain tube conveniently rotates at 360° radius to allow ease-of-connection with any floor water drain position

(Application) capacity is calculated on 90% of total volume in the cubic feet x 34 lb/ft<sup>3</sup> - 545 kg/m<sup>3</sup>.

(AHRI) capacity is calculated on 80% of total volume in the cubic feet x 30 lb/ft<sup>3</sup> - 481 kg/m<sup>3</sup>.

Model	Ice Capacity (Application)		Ice Capacity (AHRI)		Internal Volume (m <sup>3</sup> )	Dimensions (mm) [WxDxH]
	[kg]	[lbs]	[kg]	[lbs]		
SB 948	406	893,2	319	701,8	0.83	1236x868x1274
						48 5/8" x 34 3/16" x 50 1/8"

This product qualifies for the following listings:



**2** Years Warranty

Subject to certain limitations and exclusions

Certified ISO 9001

[www.scotsman-ice.it](http://www.scotsman-ice.it)  
[www.scotsman-ice.com](http://www.scotsman-ice.com)

Models and specifications are subject to change without notice.

## Storage capacity 406 Kg

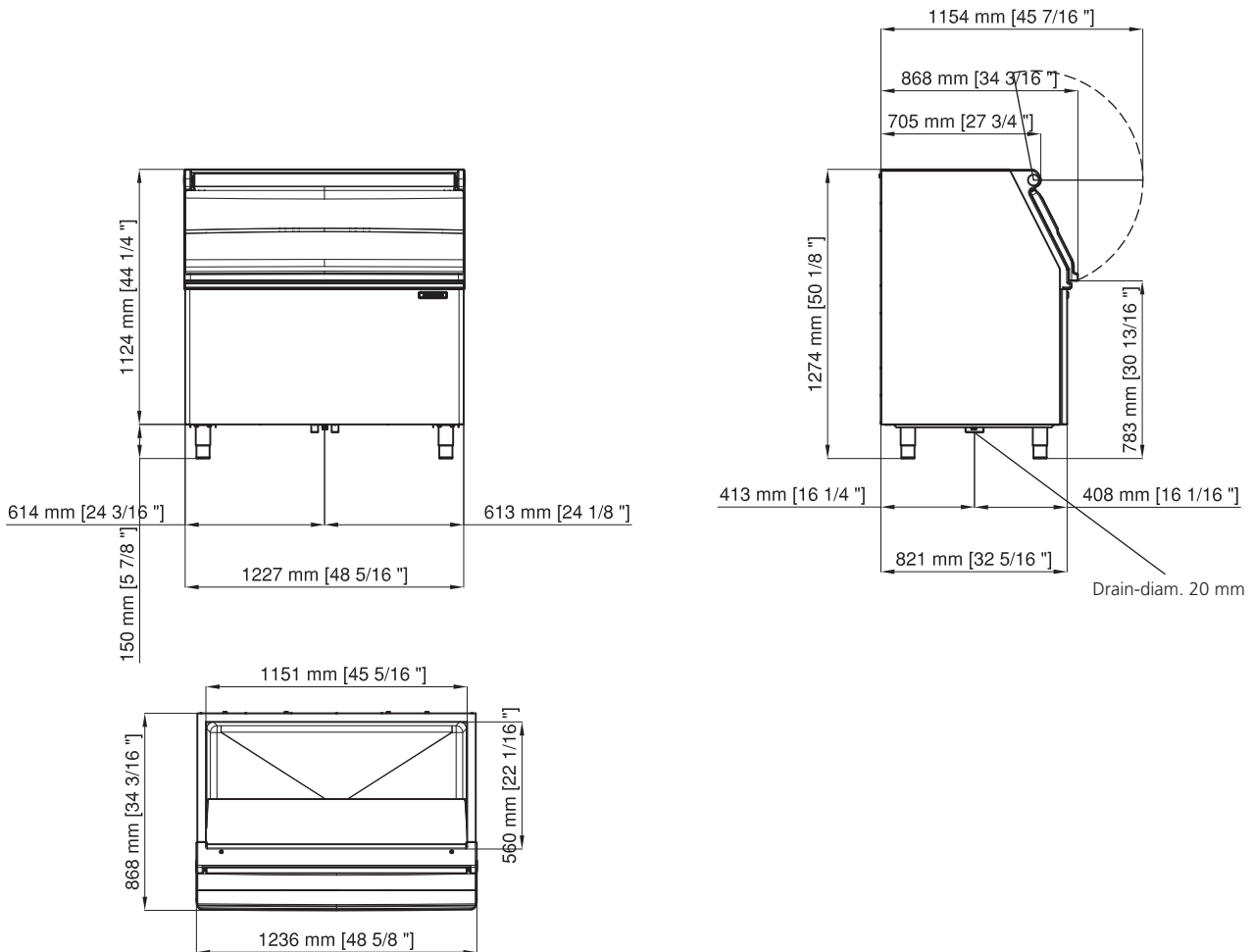

	 [kg]    [lbs]		 [kg]    [lbs]	
SB 948	73	160,6	97	213,4

**IMPORTANT NOTICE:**  
Models and specifications are subject to change without notice.  
This spec sheet is meant for commercial purpose only.  
For technical documentation please refer to our service manuals.

[www.scotsman-ice.it](http://www.scotsman-ice.it)  
[www.scotsman-ice.com](http://www.scotsman-ice.com)

**Scotsman®**  
Ice Systems