



POTATO PEELER M-5

5 Kg. / 11 pounds load per cycle.



- ✓ Depth: 367 mm
- ✓ Height: 490 mm

External dimensions with stand

- ✓ Width with stand: 425 mm
- ✓ Depth with stand: 555 mm
- ✓ Height with stand: 965 mm

Plate speed: 300 rpm

Net weight: 15.5 Kg

Crated dimensions

57 x 42 x 42 mm

Gross weight: 18.5 Kg

AVAILABLE MODELS

1000565 Potato peeler M-5 230/50-60/1

* Ask for special versions availability

SALES DESCRIPTION

Commercial stainless steel construction potato peeler suitable for reduced space areas. Also suitable to peel carrots and other similar products.

- ✓ Abrasive peeling. The abrasive is highly resistant and long lasting.
- ✓ Base Plate lined with highly resistant and long lasting abrasive.
- ✓ Stainless steel body.
- ✓ Ideal for placement near sink for drainage
- ✓ Very easy to install
- ✓ Water inlet system with non-return air break.
- ✓ Integral control panel complete with on/off push buttons and a 0-6 minute timer.
- ✓ Optional extra: A stainless steel stand complete with removable filter chamber.

OPTIONAL

- Stainless steel floor stand.
- Filter with no-foam feature.

ACCESSORIES

- Stands for potato peelers
- Filters for potato peelers M / PI / PES

SPECIFICATIONS

Hourly production: 80 Kg / 100 Kg

Capacity per load: 5 Kg

Timer (min-max): 0' - 6'

Total loading: 300 W

Noise level (1m.): 70 dB(A)

Background noise: 32 dB(A)

External dimensions (WxDxH)

- ✓ Width: 333 mm







POTATO PEELER M-5

5 Kg. / 11 pounds load per cycle.

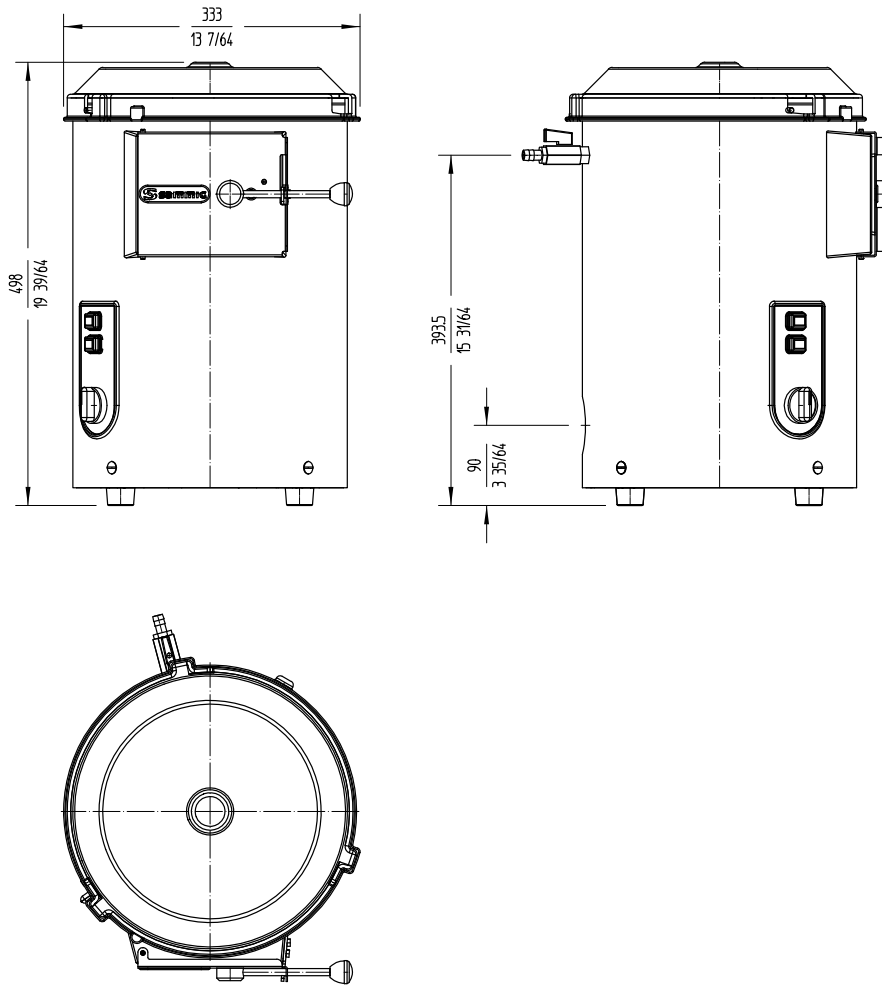

DYNAMIC PREPARATION
COMMERCIAL POTATO PEELERS



 **sammic** | www.sammic.com
Food Service Equipment Manufacturer
Polígono Basarte, 1. phone +34 943 15 72 36
20720 Azkoitia, Spain sales@sammic.com



Project	Date
Item	Qty
Approved	

product sheet
updated 15/11/2022